

Original Article

# Evaluating Learning Management System Usability Level Towards Online Learning: University Students Perspective

Bostley Muyembe Asenahabi<sup>1</sup>, Peters Anselemo Ikoha<sup>2</sup>, Alice Wechuli Nambiro<sup>3</sup>

<sup>1,2,3</sup> Department of Information Technology, Kibabii University, Bungoma, Kenya

<sup>1</sup>Department of Computer Science, Alupe University, Busia, Kenya

Received: 21 October 2022

Revised: 05 December 2022

Accepted: 19 December 2022

Published: 31 December 2022

**Abstract** - Technology has revolutionized education and brought about new modes of learning. COVID-19 played a pivotal role as a catalyst for embracing technology-enhanced learning. Adopting Learning Management Systems without considering their usability may have a negative impact on the learners' experience, and lecturers may abandon the systems and opt for alternative online learning tools. This study adopts a design science worldview, quantitative research design and survey research method. It uses a sample size of 398 randomly selected learners to participate in the study. The proportional allocation method is used to get the exact number of learners per university who are randomly selected. Quality is ensured through validity analysis and reliability testing of research instruments. Exploratory Factor Analysis is used to extract principal components and indicators mapping onto them. Based on the indicators' theme converging on the constructs, the constructs are named: Usefulness, Satisfaction, Ease of use and Learnability. This paper is essential for university management as they gradually embrace Learning Management Systems for online learning.

**Keywords** - Learning management system, Learning management system factor, Learning management system framework, Learning management system usability, Online learning.

## 1. Introduction

When online and distance learning emerged, many higher learning institutions held back their urge to adapt this technology. Despite the slow rate at which online learning was embraced when it started evolving, prestigious universities globally began offering courses, professional certificates, and college degrees online through Learning Management Systems (Ohliati & Abbas, 2019). E-learning systems are becoming acceptable tools for teaching and learning (Kiget, Wanyembi, & Ikoha, 2014). Universities have been utilizing online learning platforms to offer learners the best education delivery services in the online environment (Ortiz & Green, 2019). These online learning platforms enable lecturers and learners to embrace and appreciate knowledge sharing irrespective of where the learners are located (Rathnayaka, Silva, & Senavirathne, 2020).

The COVID-19 pandemic led to a rapid uptake of Learning Management Systems in most universities, thus changing learners' learning experience. Learners were tasked with self-study and exploring the learning content virtually. In today's ubiquitous digital environment, Learning Management Systems play an important role in enhancing and facilitating teaching and learning. Learning Management System is one of the best online learning platforms, enabling the delivery of instructions and electronic resources to improve and augment student learning in a collaborative

environment and allowing instructors to focus on designing meaningful pedagogical activities (Turnbull, Chugh, and Luck, 2021).

Many universities hurriedly adopted these technology-enabled learning tools without considering their usability, especially from the learners' and lecturers' perspectives. Despite the convenience brought by these Learning Management Systems, adopting them without considering their usability may lead to a challenge in maintaining online learner engagement remotely, negative online learning experience, deterioration of quality of learning and hence learner performance.

This study aimed to:

- Establish a Learning Management Systems Usability Factors Framework
- Analyze the usability level of learning management systems among university learners.

## 2. Literature Review

Different researchers have investigated the use of Moodle learning platform from different perspectives like technological factors; human factors; social factors, and reinforcement factors. Boateng, Mbrokoh, Boateng, Senyo, and Ansong (2016) point out that universities have adopted information technologies as mediators in teaching and



learning. This paradigm shift emphasizes using learning management systems to facilitate the learning process. E-learning systems have activities which allow learners to participate in online studies actively. If academic institutions provide e-learning platforms and services for studies, they need to be useable by the learners and lecturers.

Some usability factors that may lead to the effective use of e-learning systems are ease of use and user-friendliness. In most developing countries still in the e-learning adoption phase, it is essential to investigate the technology-facilitating constructs such as Perceived Ease of use, Perceived Usefulness, Attitude, Behavioural intentions and actual use (Boateng *et al.*, 2016). Besides, Abdullah (2017) insinuates that Technical readiness and Technical Support are the additional factors that influence attitudes and behavioural intentions to use the Moodle platform in higher learning institutions.

Wichadee (2015) performed a study in Thailand and explained that the learning management system, Moodle, enables instructors to organize their lecture content. He further elaborates that some of the usability factors that Moodle offers are effective classroom management; it is user-friendly and enhances student performance. This is in agreement with a study performed by Islam (2015) at a Finnish University about Moodle, which pointed out that the students found it user-friendly and easy to navigate through, with negligible difficulty in making use of the platform to study and perform their assignments.

A study by Thuseethan *et al.* (2014) about the usability evaluation of learning management systems in Sri Lankan Universities evaluated the usability of learning management systems with the aid of pre-defined usability standards to measure how effective learning management systems are. This study discovered that the learners liked it for its ease of access.

A study by Wang, Chen, and Khan (2014) point out that Moodle is advancing online learning to a new level by integrating cloud computing technology and mobile learning. A different study by Wang (2012) points out that Moodle is interactive as it enhances students' discussions on the platform. It has easily customizable options, easy to navigate through different sections, attractive to use, satisfies user needs, allows for the management of documents, graphics and web pages, and communication with the learners through discussion forums and students' assessments as they progress with their studies (Susana *et al.*, 2015). Issues explaining the usability factors which determine the actual use of Moodle platform range from student perceptions, perceived ease of use, perceived usefulness, attitude towards the use of Moodle and level of computer skills (Bhardwaj, Nagandla, Swe, and Abas, 2015).

In a study by Ivanović *et al.* (2013), a questionnaire was used to find out how learners and instructors viewed the usability of Moodle. It was noted that Moodle is user-friendly, easy to use, and easy to learn how to use. However, suggestions were raised about how to enhance the quality of learning material, for instance, by presenting additional examination sample questions.

In developed countries, studies by Kasim and Khalid (2016) and Bhardwa, Nagandla, Swe, and Abas (2015) revealed that usability factors that determine the actual use of Moodle platform range from student perceptions, Perceived ease of use, perceived usefulness, attitude towards the use of Moodle, level of computer skills. However, some of the challenges faced are a lack of technological skills and attitude towards using the Moodle platform.

A learning management system is a special application that enables learning to occur irrespective of place, time and distance. It possesses fundamental capabilities like lecture scheduling, disseminating knowledge, learner competency assessment, learner attainment recording, support for online social communities, communication tools, learner tracking and system security. Some learning management system usability constructs are independence in learning, efficiency, effectiveness, urge to learn, Perceived Ease of use, Perceived Usefulness and user-friendly (Asenahabi, Ikoha, & Nambiro, 2022).

### 3. Methodology

This study was based on the design science worldview, which advocated for knowledge generation through smart observation and measurement (Creswell and Creswell, 2018) of the Learning Management System usability level towards online learning with reference to university students. Based on the Quantitative research design, this study adopted a survey method to enable the researcher to collect discrete data values using questionnaires (Asenahabi *et al.*, 2019). According to Young (2017), questionnaires are used to capture a lot of data in a statistical form from many people in a relatively short time.

A simple random sampling technique was used to collect data about Learning Management System Usability factors. There were 61 universities in Kenya as of 2019 (Kenet, 2019). Singh (2006) postulates that a sample size of 10% to 20% of the accessible population is appropriate for survey research. This study used a sample size of 15% of 61 universities in Kenya (as of 2020), forming a sample size of 10 institutions. The 10 institutions had a total number of 74235 learners enrolled and studying using the online learning platforms, which represented the study population. To get the exact number of respondents who participated in the study (sample size), the study adopted a formula by Taro Yamane (1967). A confidence level of 95% was assumed.

$$n = \frac{N}{[1+N(e)^2]} \tag{1}$$

$$= \frac{74235}{1+74235 (0.05)^2} = 398 \text{ learners}$$

n = Sample size; N is the population size, and e is the level of precision - 0.05

A stratified proportional allocation method was used to ensure equality in representation with respect to the number of learners enrolled on the online learning platforms for each university. The study adopted a simple random sampling technique to pick out the respondents to ensure that the sampled entities represent the entire population.

This study adapted the Scale for Usability of Learning Management Systems (SULMS). A 29-item questionnaire with a Five-point Likert scale ranging from Strongly Disagree {1} to Strongly Agree {5} was used. To ensure the quality of the data collection tool, validity was attained through both internal validity and external validity. Reliability was ensured by carrying out a pilot study and performing an internal consistency reliability test. The internal consistency of the data collection instrument was analyzed using Cronbach's alpha, where Cronbach's alpha value for the Learning Management System Usability construct was .988 with 29 items. A Cronbach's alpha value of 0.90 and above is considered excellent reliability (Taber, 2018). This study used descriptive, exploratory, inferential and mechanistic data analysis (Asenahabi & Ikoha, 2021). Descriptive data analysis was used to summarize data elements to describe what happened in the sample. In contrast, exploratory data analysis was used for visualization and studying the data set. Exploratory Factor Analysis was used to extract constructs and indicators that converged in them. To quantify the usability scores from the respondents, the indicators were normalized using a formula – {(LMSI – 1)\*0.862} to produce a percentile ranking scale of 0 – 100, after which their mean value was calculated. A usability level score above 68 is considered above average, while a score below 68 is below average (Kaewsaiha, 2019).

#### 4. Data Analysis and Discussions

This section illustrates the data analysis process and results of the collected data.

##### 4.1. Descriptive Statistics

This study analyzed the gender and level of education of the respondents. Table 1 depicts the summarized data.

##### 4.1.1. Gender of Respondents

Data analysis based on the gender of the respondents pointed out that out of the 398 learners who took part in the study, 229 learners representing 57.5%, were male. In comparison, 169 learners representing 42.5%, were female.

**Table 1. Demographic Information**

		<b>Frequency N = 398</b>	<b>Percentage (%)</b>
<b>Gender</b>	Female	169	42.5
	Male	229	57.5
<b>Level of Education</b>	Under-graduate	278	69.8
	Postgraduate	120	30.2

**Table 2. Type of Learning Management System interacted with**

<b>LMS used</b>	<b>Frequency</b>	<b>Percent</b>
Blackboard	14	3.5
Canvas	5	1.3
Moodle	336	84.4
Sakai	43	10.8
<b>Total</b>	<b>398</b>	<b>100.0</b>

##### 4.1.2. Level of Education

The study revealed that out of the 398 respondents, 120 respondents, representing 30.15%, were postgraduate students, while 278 respondents representing 69.85%, were undergraduate students.

##### 4.2. Type of Learning Management System in use

This study constructs examined the different learning management systems used by different universities in Kenya. Respondents were asked to pick the type of learning management system they mostly interact with for studies. Table 2 – Type of Learning management system interacted with depicts the analyzed data.

Table 2 illustrates the summarized data about the learning management systems used by the respondents. Fourteen (14) respondents highlighted that they have interacted with Blackboard. Five (5) respondents pointed out that they had interacted with canvas. The majority of the respondents three hundred and thirty-six (336), 84.4%, highlighted that they mostly interact with Moodle. Forty-three (43) respondents, equivalent to 10.8%, pointed out that they interacted with Sakai.

##### 4.3. Average Time Spent Studying the Learning Management System

The study sought to determine the average daily time spent by the learners studying on the learning management system platform. The responses are as depicted in Figure 1 – Average time spent studying on the LMS.

The findings summarized in Figure 1 indicate that 15 % of the respondents pointed out that they spend less than an hour studying the learning management system on average. A majority of the respondents, 74%, take between two and four hours on average studying on the learning management system. 11% of the respondents pointed out that they spend

more than five hours on average studying the learning management system.

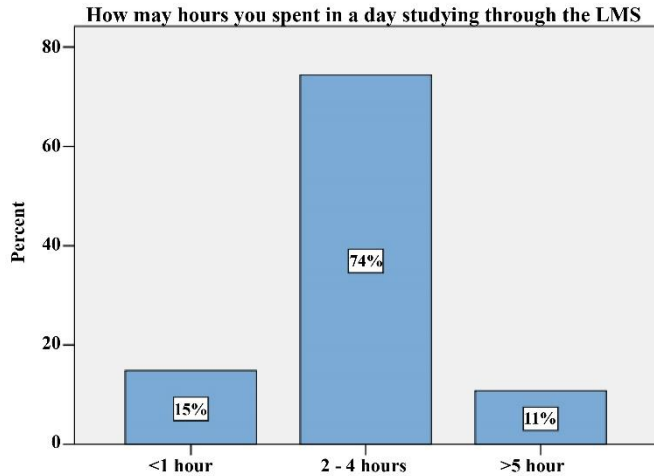

How may hours you spent in a day studying through the LMS  
 Fig. 1 Average time spent studying on the LMS

**4.4. Exploratory Factor Analysis**

This section determined the usability factors of learning management systems. This section aimed to analyze the usability of existing learning management systems used towards self-directed learning. The respondents were

required to rate their level of agreement on twenty-nine (29) different indicators on a scale ranging from Strongly agree (1); Agree (2); Undecided (3); Disagree (4) to Strongly disagree (5). The responses were summarized and analyzed to extract principal components and their corresponding indicators using exploratory factor analysis.

**4.5. Construct Extraction**

To determine the number of components to be extracted, the researcher used three different methods: Kaisen criteria, Scree plot and Parallel analysis. Table 3 – Learning management system total variance explained illustrates the summarized and analyzed data through Kaisen criteria.

Table 3 depicts the summarized and analyzed data using kaisen criteria. Five components have an eigenvalue greater than one (1).

Figure 2 – Learning Management System Scree plot illustrates the summarized and analyzed data.

Based on Figure 2, the first kink appears at the second component.

**Table 3. Learning management system Total Variance Explained**

Component	Initial Eigenvalues		
	Total	% of variance	Cumulative %
1	13.643	47.044	47.044
2	1.953	6.735	53.780
3	1.649	5.685	59.465
4	1.443	4.976	64.441
5	1.097	3.781	68.222
6	.858	2.958	71.180
7	.823	2.838	74.018

Extraction Method: Principal Component Analysis.

**Table 4. Learning Management System parallel analysis**

Eigen Value #	Random Eigen Value	Std Deviation
1	1.5823	0.0481
2	1.4966	0.0363
3	1.4302	0.0285
4	1.3788	0.0280
5	1.3263	0.0244
6	1.2843	0.0230

The third method used for determining the number of components was parallel analysis. Principal Component Analysis for Parallel Analysis was used to generate Table 4 – Learning Management System parallel analysis.

The random eigenvalues generated by parallel analysis – In table 4 were compared with the values generated using Kaisen criteria in Table 3. The comparison points out that the first four (4) values of the kaisen criteria are greater than those of parallel analysis. The fifth value of the parallel analysis is greater than that of the kaisen criteria. The first four components generated through Kaisen criteria were retained while the other components were discarded. This implies that this study adopted four components for this construct.

**4.6. Factorability of the Correlation Matrix**

A survey on communalities extractions points out that all coefficients are greater than 0.3; thus, all the values are retained. There was no need to refine the scale.

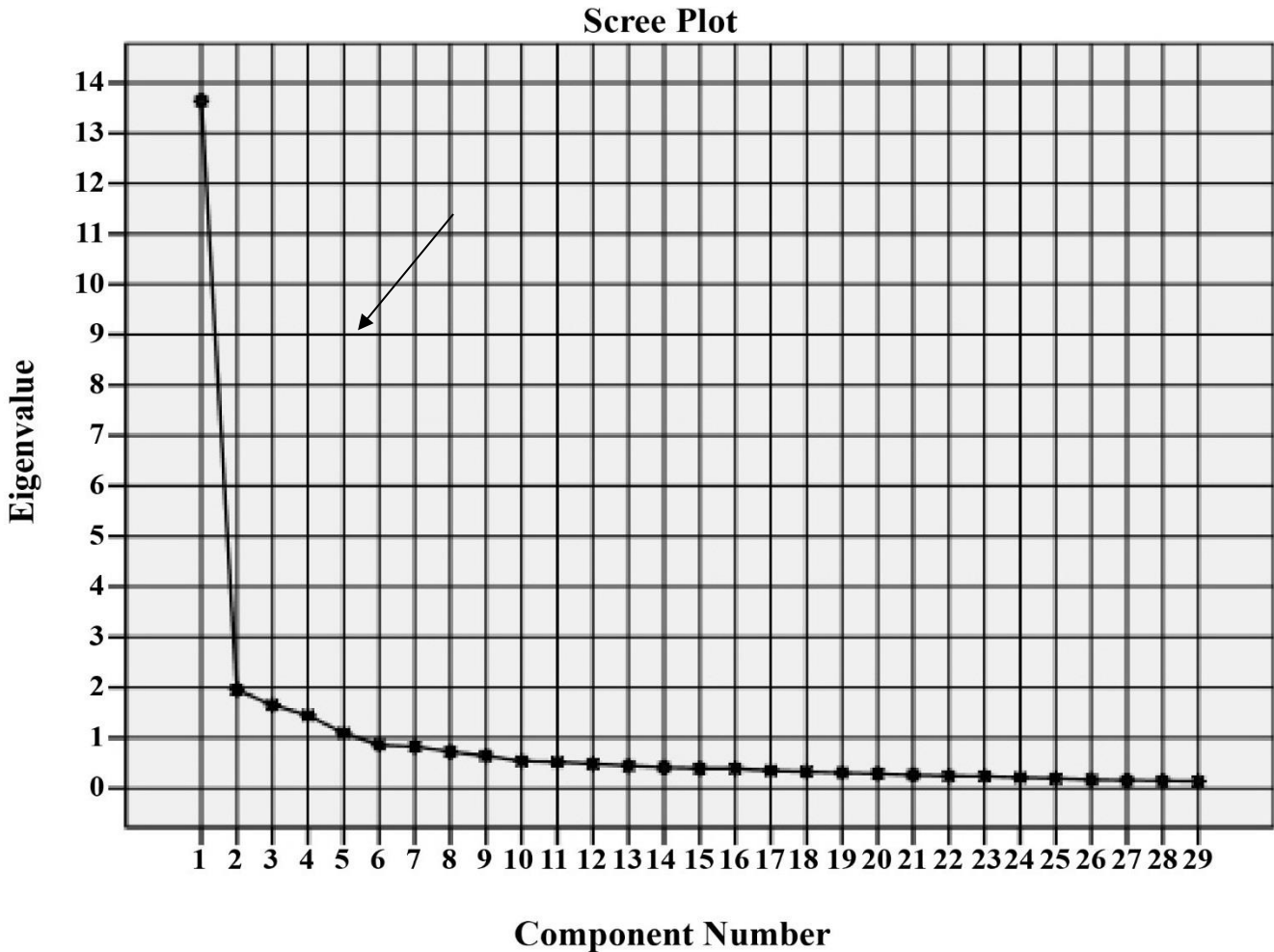

Fig. 2 Learning Management System Scree plot

**4.7. Suitability of Data for Factor Analysis**

To determine if the sampled data is suitable for factor analysis, the Kaiser-Meyer-Olkin measure of sampling adequacy and Bartlett's test of sphericity were performed. Table 5 – Learning management system KMO and Bartlett's test illustrates the results of this analysis.

Table 5 - KMO and Bartlett's Test depicts that the Kaiser-Meyer-Olkin Measure of sampling adequacy value is 0.940. This implies that 94.0% of the variability can be explained by the underlying factors. Besides, Bartlett's test of Sphericity significant (p) value is 0.000, a value much less than 0.05. Having a KMO value greater than 0.6 and a significant Bartlett's test of Sphericity value implies enough variance in the data; the data is scalable and can be subjected to factor analysis.

**4.8. Factor Extraction**

The Rotated Component Matrix shows how the indicators map the components. Table 6 - The learning

management system rotated component matrix indicates the analysis for this study.

Table 6 analysis was based on the principal component analysis extraction method and varimax with Kaiser normalization rotation, with the rotation converging in eleven (11) iterations. Based on the data analysis, ten (10) indicators converged in the first component.

Table 5. Learning management system KMO and Bartlett's test

KMO and Bartlett's test		
Kaiser-Meyer-Olkin Measure of Sampling Adequacy.		.940
Bartlett's Test of Sphericity	Approx. Chi-Square	7551.905
	df	406
	Sig.	.000

**Table 6. Learning management system Rotated Component Matrix<sup>a</sup>**

	Component			
	1	2	3	4
It helps me to be more effective in studies	.688			
It helps me to be more productive in studies	.773			
It is useful	.640			
It gives me more control over the activities in my life	.643			
It makes the things I want to accomplish easier to get done	.742			
It saves me time when I use it	.790			
It meets my learning needs	.723			
It does everything I expect it to do	.582			
It is flexible	.417			
Both occasional and regular users would like it	.422			
I quickly became skilful with it		.546		
I am satisfied with it		.620		
I would recommend it to a friend		.637		
It is fun to use		.742		
It works the way I want it to work		.526		
It is wonderful		.654		
I feel I need to have it		.655		
It is pleasant to use it		.692		
It is easy to use			.739	
It is simple to use			.762	
It takes the fewest steps to accomplish what I want it to			.665	
It is user friendly			.501	
I easily remember how to use it			.591	
It is easy to learn to use it			.638	
I learned to use it quickly			.594	
Using it is effortless				.642
I do not need to go through written instructions to use it				.631
I haven't come across inconsistencies as I use it				.815
I use it successfully every time				.702
Extraction Method: Principal Component Analysis. Rotation Method: Varimax with Kaiser Normalization.				
a. Rotation converged in 11 iterations.				

These indicators were: 'It helps me to be more effective in studies' with a loading coefficient of 0.688; 'It helps me to be more productive in studies' with a loading coefficient of 0.773; 'It is useful' with a loading coefficient of 0.640; 'It gives me more control over the activities in my life' with a loading coefficient of 0.643; 'It makes the things I want to accomplish easier to get done' with a loading coefficient of 0.742; 'It saves me time when I use it' with a loading coefficient of 0.790; 'It meets my learning needs' with a loading coefficient of 0.723; 'It does everything I expect it to do' with a loading coefficient of 0.582; 'It is flexible' with a loading coefficient of 0.417 and 'Both occasional and regular users would like it' with a loading coefficient of 0.422. These ten (10) indicators converge in an attribute related to how

useful the learning management system is; thus, the first component was renamed 'Usefulness'. Therefore, the Usefulness construct had an average loading coefficient of  $(0.688 + 0.773 + 0.640 + 0.643 + 0.742 + 0.790 + 0.723 + 0.582 + 0.417 + 0.422) / 10 = 0.642$

The second component has eight (8) indicators converging in it. These indicators were: 'I quickly became skilful with it' with a loading coefficient of 0.546; 'I am satisfied with it' with a loading coefficient of 0.620; 'I would recommend it to a friend' with a loading coefficient of 0.637; 'It is fun to use' with a loading coefficient of 0.742; 'It works the way I want it to work' with a loading coefficient of 0.526; 'It is wonderful' with a loading coefficient of 0.654; 'I feel I need to have it' with a loading

coefficient of 0.655 and 'It is pleasant to use it' with a loading coefficient of 0.692. These eight (8) indicators converge in an attribute related to how the respondents are satisfied with the system. Thus, the second component was renamed 'Satisfaction'. Therefore, the Satisfaction construct had an average loading coefficient of  $(0.546 + 0.620 + 0.637 + 0.742 + 0.526 + 0.654 + 0.655 + 0.692) = 0.634$

The third component had seven (7) indicators converging on it. These indicators were: 'It is easy to use' with a loading coefficient of 0.739; 'It is simple to use' with a loading coefficient of 0.762; 'It requires the fewest steps possible to accomplish what I want it to' with a loading coefficient of 0.665; 'It is user friendly' with a loading coefficient of 0.501; 'I easily remember how to use it' with a loading coefficient of 0.591; 'It is easy to learn to use it' with a loading coefficient of 0.638 and 'I learned to use it quickly' with a loading coefficient of 0.594. These seven (7) indicators converge to an attribute related to how easy it is for the users to interact with. Thus, the third component was renamed 'Ease of Use'. Therefore, the Ease of Use construct had an average loading coefficient of  $(0.739 + 0.762 + 0.665 + 0.501 + 0.591 + 0.638 + 0.594) = 0.641$

The fourth component had four (4) indicators converging on it. These indicators were: 'Using it is effortless' with a loading coefficient of 0.642; 'I do not need to go through written instructions to use it' with a loading coefficient of 0.631; 'I haven't come across inconsistencies as I use it' with a loading coefficient of 0.815 and 'I use it successfully every time' with a loading coefficient of 0.702. These four indicators converge on an attribute related to the learning characteristics of the respondents as they use the system. Thus, the fourth component was renamed 'Learnability'. Therefore, the Learnability construct had an average loading coefficient of  $(0.642 + 0.631 + 0.815 + 0.702) = 0.698$

The weights of the factor loadings were calculated by evaluating the ratio of each factor loading to the total factor loading, as illustrated in Table 7. Based on the analysis, the constructs and their respective factor loadings and weights are indicated in Table 7 – LMS Usability Factor Loadings and Weights.

Based on this analysis, the usability of the learning management system can be attributed to four factors, as illustrated in Figure 3 – Learning Management System Usability Factors Framework

Figure 3 depicts that the learning management system is attributed to four factors: usefulness; satisfaction; learnability, and ease of use, with each of them having multiple indicators, as shown in Table 8 – Learning Management System Usability factors' indicators.

**Table 7. LMS Usability Factor Loadings and Weights**

LMS Usability Factors	Loading	Weight
Usefulness	0.642	0.245
Satisfaction	0.634	0.243
Learnability	0.698	0.267
Ease of Use	0.641	0.245
<b>Total Factor Loading</b>	<b>2.615</b>	<b>1.000</b>

**Table 8. Learning Management System Usability factors' indicators**

<b>Usefulness Indicators</b>
It helps me to be more effective in studies It helps me to be more productive in studies It is useful It gives me more control over the activities in my life It makes the things I want to accomplish easier to get done It saves me time when I use it It meets my learning needs It does everything I expect it to do It is flexible Both occasional and regular users would like it
<b>Satisfaction Indicators</b>
I quickly became skilful with it I am satisfied with it I would recommend it to a friend It is fun to use It works the way I want it to work It is wonderful I feel I need to have it It is pleasant to use it
<b>Ease of Use Indicators</b>
It is easy to use It is simple to use It takes few steps to do what I want it to I easily remember how to use it It is easy to learn to use it I learned to use it quickly It is user friendly
<b>Learnability Indicators</b>
Using it is effortless I do not need to go through written instructions to use it I haven't come across inconsistencies as I use it I use it successfully every time

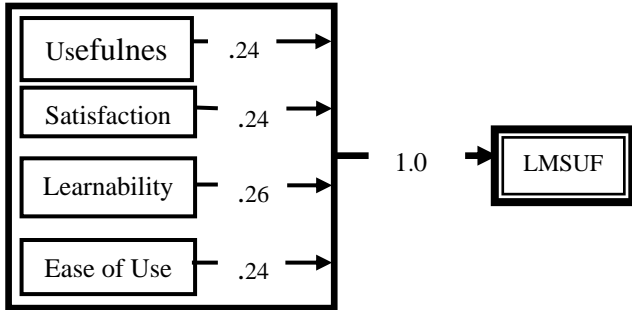

Fig. 3 Learning Management System Usability Factors Framework

#### 4.5 Learning Management System Usability Level

The Scale for Usability of Learning Management Systems was used to rate the level of usability of the different Learning Management Systems used in universities in Kenya. Table 9 - Scale for Usability of Learning Management System depicts the summarized data.

Table 9. Scale for Usability of Learning Management System

LMS Platform	No of Respondents	Mean Score (0 - 100)
Moodle	336	73.8
Sakai	43	72.5
Blackboard	14	63.9
Canvas	5	61.2
<b>Total</b>	<b>398</b>	<b>73.4</b>

Data summary and analysis in Table 9 indicate the usability mean scores for the individual learning management system platforms and the overall learning management system usability level. To quantify the usability level of the respondents, the responses were normalized using a formula –

$$\{(LMSI - 1) * 0.862\} \quad (2)$$

#### References

- [1] Mohammed Simko Abdullah, "Analysis of the Factors for the Successful E-Learning Services Adoption from Education Providers' and Students' Perspectives: A case study of Private Universities in Northern Iraq," *Eurasia Journal of Mathematics, Science and Technology Education*, vol. 14, no. 3, pp. 1097 – 1109, 2017, *Crossref*, <https://doi.org/10.12973/ejmste/81554>
- [2] Bostley Myuembe Asenahabi, and Peters Anselemo Ikoha, "Scientific Levels of Field Data Analysis in Computing Research," *The International Journal of Science and Technoledge*, vol. 9, no. 11, pp. 18 – 23, 2021, *Crossref*, <https://doi.org/10.24940/theijst/2021/v9/i11/ST2111-008>
- [3] Bostley Myuembe Asenahabi, Annette Obukosia Busula, and Richard Ronoh, "A choice dilemma in selecting an appropriate research design," *International Journal of Advanced Research in Computer Engineering and Technology (IJARCET)*, vol. 8, no. 8, pp. 348 – 356, 2019.
- [4] Bostley Myuembe Asenahabi, Peters Anselemo Ikoha, and Alice Wechuli Nambiro, "Learning Management System Usability Towards Online Learning: A Literature Review," *World Journal of Engineering Research and Technology*, vol. 8, no. 7, pp. 17 – 30, 2022.
- [5] A. Bhardwaj et al., "Academic Staff Perspectives Towards Adoption of E-learning at Melaka Manipal Medical College: Has E-learning Redefined our Teaching Model?," *Kathmandu University medical journal*, vol. 13, no. 49, pp. 12 – 18, 2015. *Crossref*, <https://doi.org/10.3126/kumj.v13i1.13746>

Where the LMSI stands for Learning Management System Indicator value to produce a percentile ranking scale of 0 – 100, after which their mean score was calculated.

Moodle had the largest number of respondents at 84.4 %, with a mean usability value of 73.8. Sakai had 10.8 % of the respondents, with a mean usability value of 72.5. Blackboard had fourteen (14) respondents with a mean usability value of 63.9. Five (5) respondents claimed to have majorly interacted with canvas, and its mean usability value was rated at 61.2.

Based on the analyzed data, Moodle and Sakai had usability values above the threshold – of 68 (Kaewsaiha, 2019), implying that their usability scores are above average. On the other hand, Blackboard and Canvas had usability values below average. In general, the mean score for the usability of Learning Management Systems used in universities in Kenya is above average – 73.4. This implies that learners are comfortable using the Learning Management Systems for their online studies, especially the Moodle and Sakai Learning Management systems.

#### 5. Conclusion

Learning management systems can be attributed to four factors: usefulness; satisfaction; learnability, and ease of use. The usability level of learning management systems was high – 73.4 based on a threshold level of 68.0. This implies that the learners perceive the learning management systems to be useful in their studies; they are easy to use, it is easy to learn how to use them, and they are also satisfied with the functioning of the learning management systems.

#### Funding Statement

The authors of this document have funded this study and publication.



- [6] Bhardwaj, A., Nagandla, K., Swe, K., and Abas, A. (2015). Academic Staff Perspectives Towards Adoption of E-learning at Melaka Manipal Medical College: Has E-learning Redefined our Teaching Model? *Kathmandu University medical journal*, 13(1), 12 - 18.
- [7] Richard Boateng et al., "Determinants of e-Learning Adoption among Students of Developing Countries," *The International Journal of Information and Learning Technology*, vol. 33, no. 4, pp. 248 – 262, 2016. *Crossref*, <https://doi.org/10.1108/IJILT-02-2016-0008>
- [8] John W. Creswell, and J. David Creswell, *Research Design: Qualitative, Quantitative and Mixed Methods Approaches* (5th ed.). Thousand Oaks, CA: Sage, 2017.
- [9] A.K.M. Najmul Islam, "The Moderation Effect of User-Type (Educators vs. Students) in Learning Management System Continuance," *Behaviour and Information Technology*, vol. 34, no. 12, pp. 1160-1170, 2015. *Crossref*, <https://doi.org/10.1080/0144929X.2015.1004651>
- [10] Mirjana Ivanovic et al., "Usability and Privacy Aspects of Moodle: Students' and Teachers' Perspective," *Informatica*, vol. 37, no. 3, pp. 221 – 230, 2013.
- [11] Pongrapee Kaewsaiha, "Usability of the Learning Management System and Choices of Alternative," *6th International Conference on Education and Psychological Sciences (ICEPS 2019)*. Tokyo, Japan, 2019.
- [12] Suman Sharma, Yogesh Verma, "Impact Of Social Network Analysis In E-Learning," *SSRG International Journal of Computer Science and Engineering*, vol. 6, no. 8, pp. 1-6, 2019. *Crossref*, <https://doi.org/10.14445/23488387/IJCSE-V6I8P101>
- [13] Nurul Nadirah Mohd Kasim, and Fariza Khalid, "Choosing the Right Learning Management System (LMS) for the Higher Education Institution Context: A Systematic Review," *International Journal of Emerging Technologies in Learning (IJET)*, vol. 11, no. 6, pp. 55 – 61, 2016, *Crossref*, <https://doi.org/10.3991/ijet.v11i06.5644>
- [14] Kenet. (2019). *Kenya Education Network*.
- [15] Nicholas Kipkurui Kiget, G. Wanyembi and Anselemo Ikoha Peters, "Evaluating Usability of E-Learning Systems in Universities," *International Journal of Advanced Computer Science and Applications*, vol. 5, no. 8, pp. 97 – 102, 2014. *Crossref*, <https://dx.doi.org/10.14569/IJACSA.2014.050815>
- [16] Jenny Ohliati, and Bahtiar Saleh Abbas, "Measuring Students Satisfaction in Using Learning Management System," *International Journal of Emerging Technologies in Learning (IJET)*, vol. 14, no. 4, pp. 180-189, 2019. *Crossref*, <https://doi.org/10.3991/ijet.v14i04.9427>
- [17] Sergio Ordiz, and Marybeth Green, "Trends and Patterns of Mobile Learning: A Study of Mobile Learning Management System Access," *Turkish Online Journal of Distance Education (TOJDE)*, vol. 20, no. 1, pp. 161 – 176, 2019. *Crossref*, <https://doi.org/10.17718/tojde.522464>
- [18] Rathnayake et al., "Feasibility Study of Hologram Gamification in Sri Lankan Higher Education Distance Learning," *General Sir John Kotelawala Defence University, 13th International Research Conference*, 2020.
- [19] Yogesh Kumar Singh, *Fundamental of Research Methodology and Statistics*, New Delhi: New Age International Publishers.
- [20] Susana Olmas et al., "Improving Graduate Students' Learning through the Use of Moodle," *Academic Journals*, vol. 10, no. 5, pp. 604 – 614, 2015. *Crossref*, <https://doi.org/10.5897/ERR2014.2052>
- [21] Mahendra A Sethi, Santosh S Lomte, "An Interactive Dynamic eLearning Framework for Visual and Verbal Learners," *SSRG International Journal of Computer Science and Engineering*, vol. 4, no. 7, pp. 3-13, 2017. *Crossref*, <https://doi.org/10.14445/23488387/IJCSE-V4I7P102>
- [22] Taber, K.S., "The Use of Cronbach's Alpha When Developing and Reporting Research Instruments in Science Education," *Research in Science Education*, vol. 48, pp. 1273 – 1296, 2018. *Crossref*, <https://doi.org/10.1007/s11165-016-9602-2>
- [23] Selvarajah Thuseethan, Sivabalan Achchuthan, and Sinnathampy Kuhanesan, *Usability Evaluation of Learning Management Systems in Sri Lankan Universities*. Arxiv, p.12, 2020. *Crossref*, <https://doi.org/10.48550/arXiv.1412.0197>
- [24] Darren Turnbull, Ritesh Chugh, and Jo Luck, J., "Learning management systems: a review of the research methodology literature in Australia and China," *International Journal of Research and Method in Education*, vol. 44, no. 2, pp. 164 – 178, 2021. *Crossref*, <https://doi.org/10.1080/1743727X.2020.1737002>
- [25] Viktor Wang, *Technology and its impact on educational leadership: Innovation and Change*, Florida Atlantic, USA: IGI Global, 2012. *Crossref*, <https://doi.org/10.4018/978-1-4666-0062-1>
- [26] Minjuan Wang, Yong Chen, and Muhammad Jahanzaib Khan, "Mobile Cloud Learning for Higher Education a Case Study of Moodle in the Cloud," *International Review of Research in Open and Distance Learning*, vol. 15, no. 2, pp. 141 – 149, 2014. *Crossref*, <http://dx.doi.org/10.19173/irrodl.v15i2.1676>
- [27] Saovapa Wichadee, "Factors Related to Faculty Member's Attitude and Adoption of a Learning Management System," *TOJET: The Turkish Online Journal of Educational Technology*, vol. 14, no. 4, pp. 53 – 61, 2015.
- [28] Young, T.J., "Questionnaires and Surveys. In H. Zhu," *Research Methods in Intercultural Communication - A Practical Guide*. New Delhi, India: Wiley Blackwell, pp. 165-180, 2015. *Crossref*, <https://doi.org/10.1002/9781119166283.ch11>